



Chapter 8

End Effectors

Objectives

By the end of this lesson the learner should be able to:

- Discuss robotic end effectors and how they are similar / different from the movements of a human hand
- Identify and explain the operation of various types of grippers used in robotic applications
- Describe the difference between end effector grippers and end effector tooling
- Identify and explain the benefits of changeable end effectors
- List important factors and desirable characteristics to be considered in the design of robotic end effectors

Prehensile Gripping



Palmar Grip



Cylindrical Grip



Spherical Grip

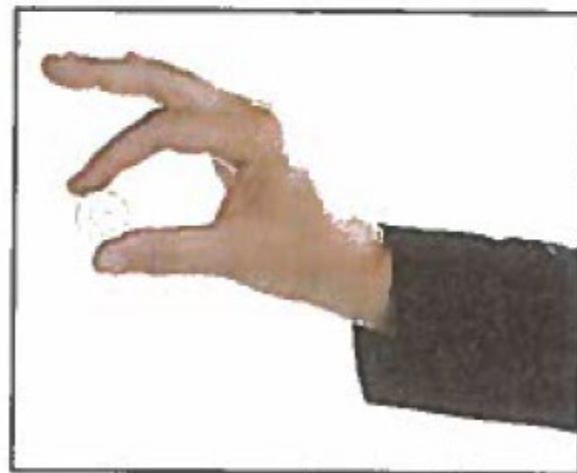

Lateral Grip

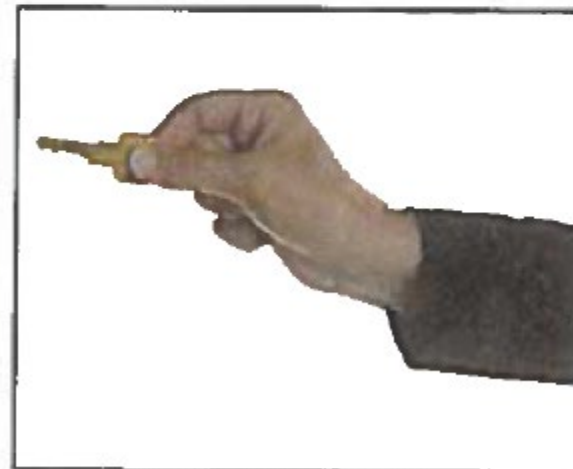

Oppositional Grip

Non-prehensile Gripping



Hook



Spread

End Effector Gripper Configurations

Gripper End Effectors			
Gripper Type	Gripper Configuration	Gripper Movement	Internal/External Gripping
Mechanical finger	Two-finger Three-finger Four-finger	Parallel or angular	Internal and external
Collet	Round Square Hexagonal	360° clamping contact	Internal and external
Vacuum	One or more suction cups	Vacuum/suction	External
Electromechanical	Permanent magnet Electromagnet	Magnetic attraction	External

Mechanical Finger Grippers

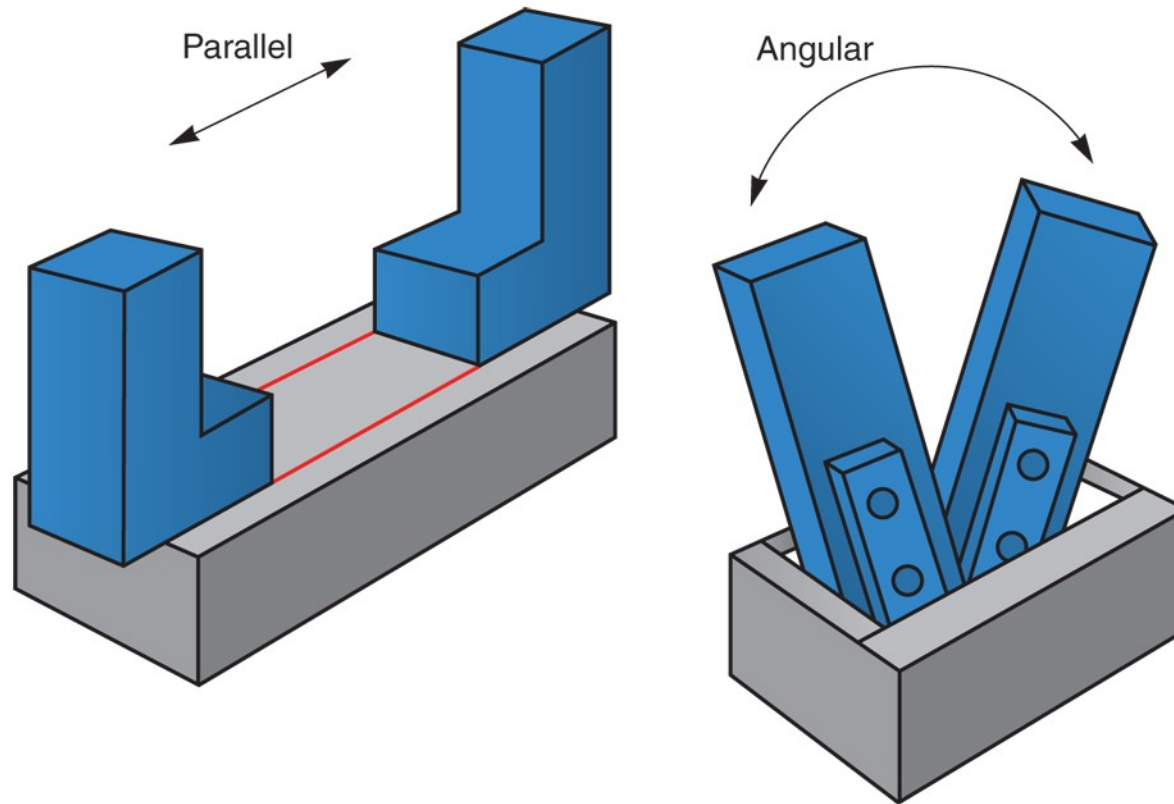

LS 8-1

Hydraulic Two Finger Gripper



Two Finger Gripper with Rotation



Two-finger Gripper

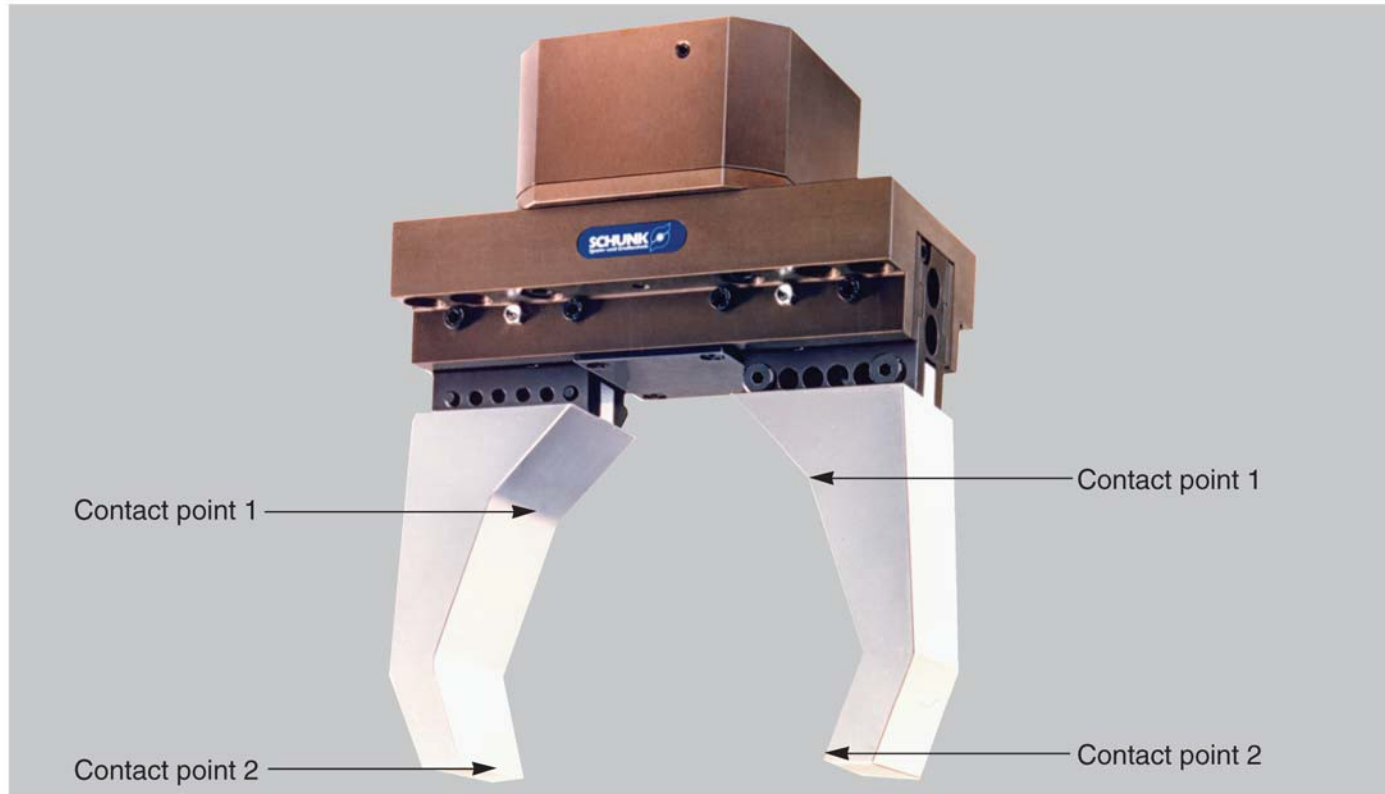

Three-finger Grippers



Vacuum Gripper

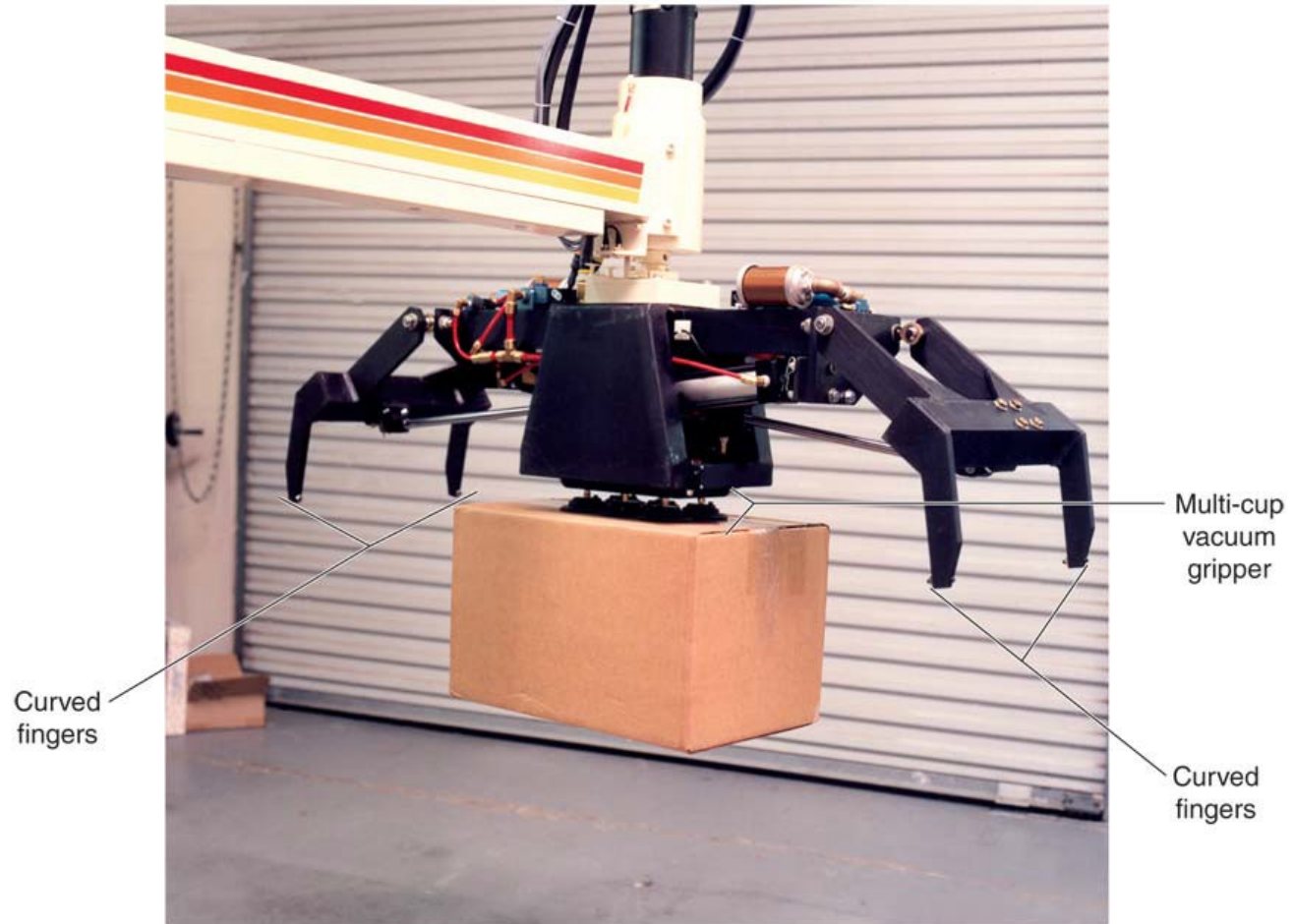

Automatic Tool Changer

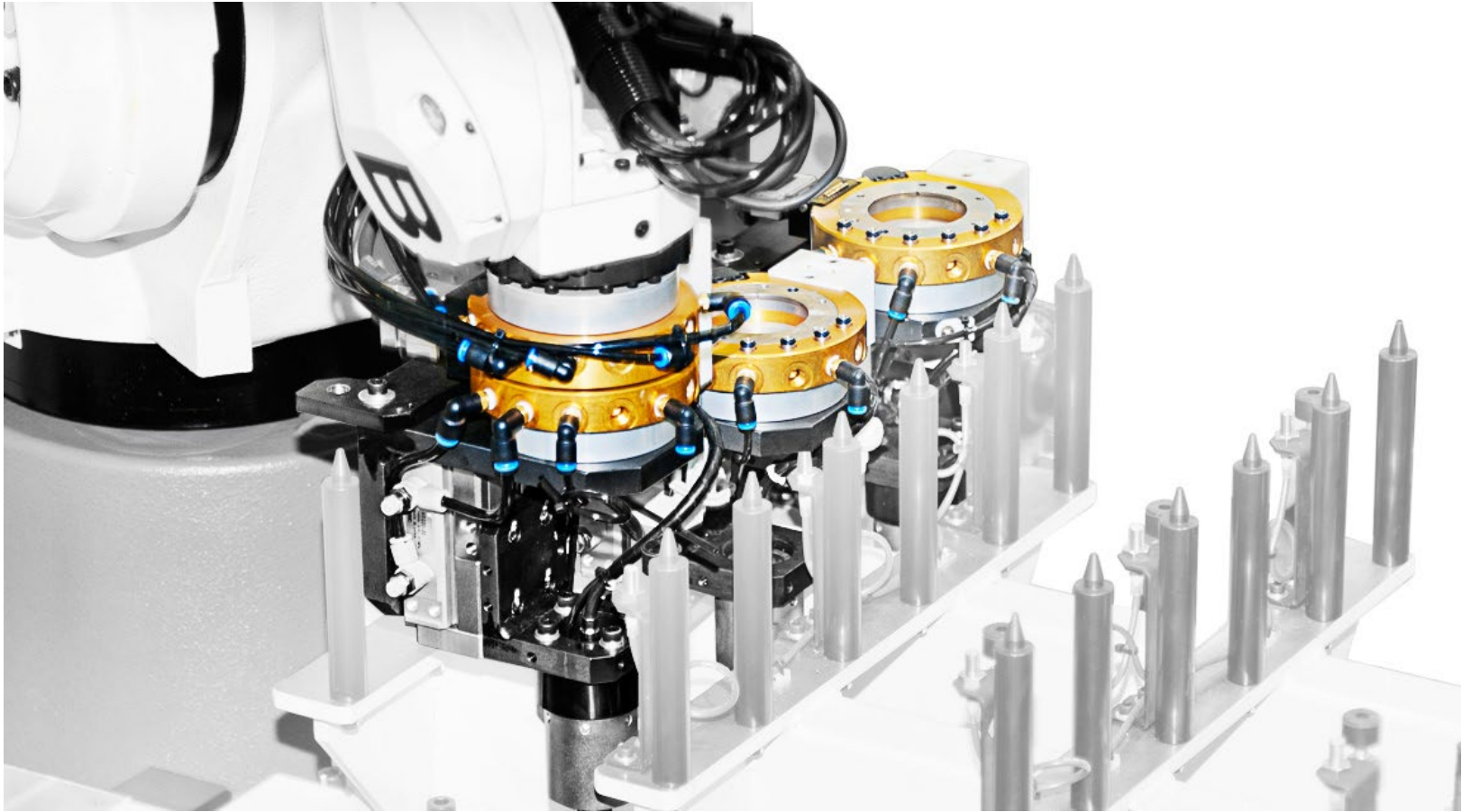

Custom Design End Effectors

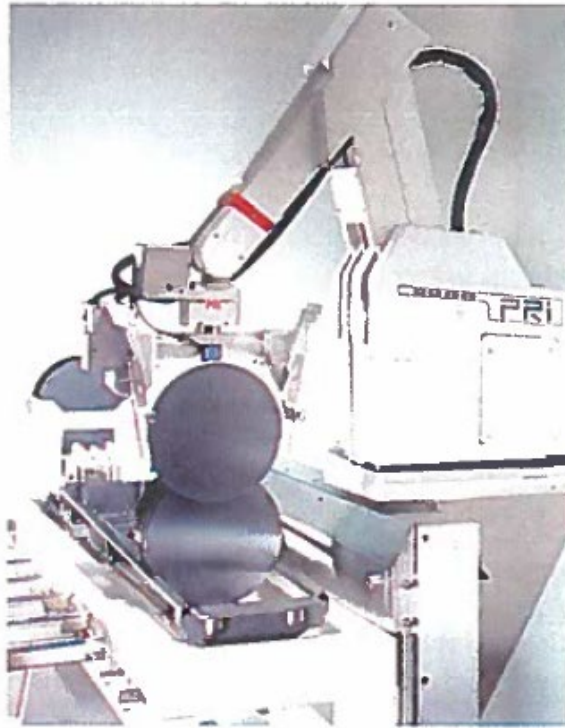

A

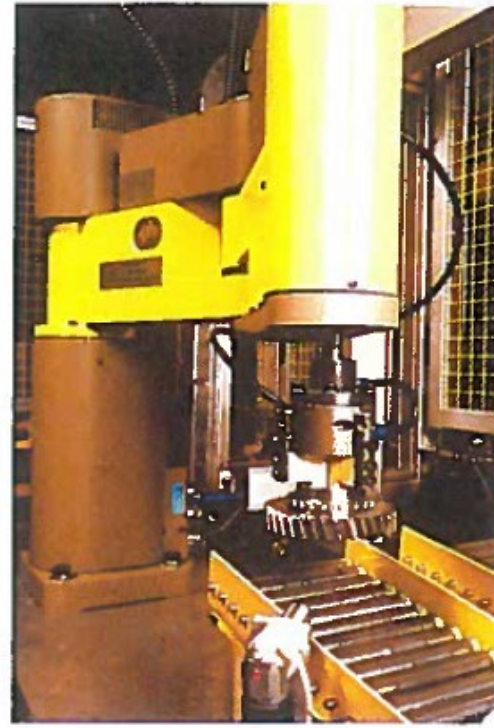

B

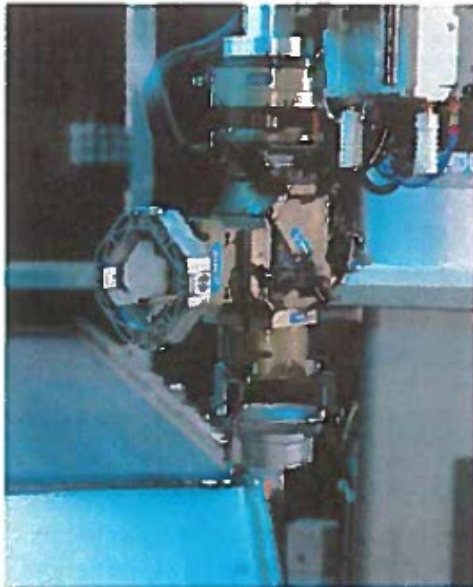

C



D

Vacuum Gripper with Vision Guidance



CyberKnife System

